

4. Recheck the brake lever free play. If free play is still excessive after adjusting the brake lining clearance, there is probably air in the brake system and it must be bled out. See your authorized Honda dealer for this service.

Adjustment:

1. Pump the brake lever 2-3 times firmly and release it.
2. Remove the adjusting hole cap (1).
3. Turn both brake shoe adjusters (2) up with a screwdriver until the front brake locks.

NOTE:

- * Do not work on both adjusters at the same time.

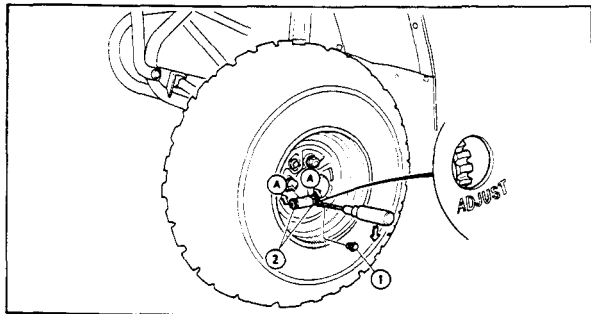

- (1) Adjustment hole cap (2) Adjusters
(A) Brake locks

4. Back the adjusters off three clicks and pump the brake lever several times.
5. Turn the wheel manually and make sure it does not drag.
6. Adjust the other front brake.
7. Install the rubber cap.

Brake Fluid Level:

WARNING

- * *Brake fluid may cause irritation. Avoid contact with skin or eyes. In case of contact, flush thoroughly with water and call a doctor if your eyes were exposed.*

Remove the screws, reservoir cover, and diaphragm. Whenever the level is near the lower level mark (3) on the reservoir, fill the reservoir with DOT 3 or 4 BRAKE FLUID from a sealed container up to the upper level mark (4). Reinstall the diaphragm and cover. Tighten the screws securely.

CAUTION

- * *When adding brake fluid, be sure the reservoir is horizontal before the cover is removed or brake fluid may spill out.*