

Drive Chain Rollers

1. Check the drive chain roller (1) for wear or damage.
2. Measure the outer diameter of the drive chain roller and replace it if below the service limit.
Service Limit: 0.7 in (18 mm)

Replace the roller if necessary as follows.

Remove the bolt (2), washers (3), collar (4) and drive chain roller.

Install a new drive chain roller, collar, washers and tighten the bolt.

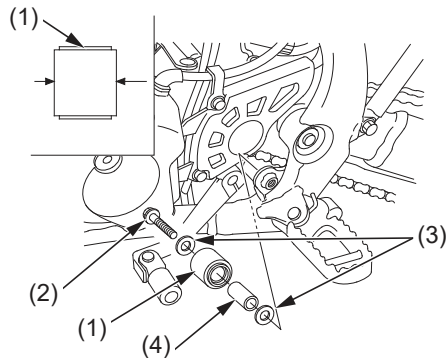

- | | |
|------------------------|-------------|
| (1) drive chain roller | (3) washers |
| (2) bolt | (4) collar |

Adjustment

1. Loosen the rear axle nut (1).
2. Loosen both chain adjuster lock nuts (2) and turn the adjusting bolts (3) counterclockwise to decrease slack or clockwise to increase slack. Align the index marks (4) of the axle plates (5) with the same reference marks (6) on both sides of the swingarm.

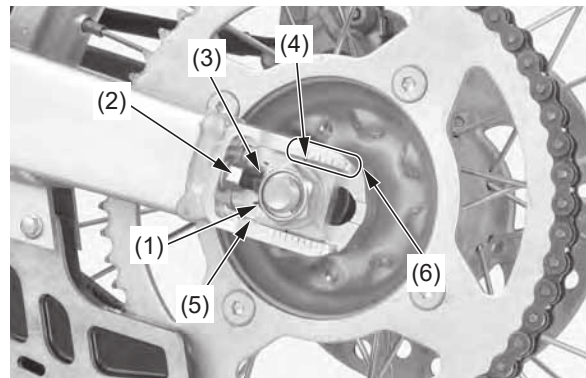

- | | |
|-----------------------------|--------------------|
| (1) rear axle nut | (4) index mark |
| (2) chain adjuster lock nut | (5) axle plate |
| (3) adjusting bolt | (6) reference mark |

3. Tighten the rear axle nut to the specified torque:
65 lbf·ft (88 N·m, 9.0 kgf·m)
4. Recheck chain slack and adjust as necessary.
5. Turn the adjusting bolts counterclockwise until it touches the axle plates lightly. Then tighten the chain adjuster lock nut to the specified torque while holding the adjusting bolt with a wrench:
20 lbf·ft (27 N·m, 2.8 kgf·m)

Lubrication

Commercially prepared drive chain lubricants may be purchased at most motorcycle shops and should be used in preference to motor oil. Pro Honda HP Chain Lube or an equivalent is recommended.

Saturate each chain joint so that the lubricant penetrates the space between adjacent surfaces of the link plates and rollers.

